

### Panic Exit Hardware

#### Introduction

Briton 560 panic exit devices have been designed to offer modular solutions for mid to high-end specification, providing a combination of style, safety and optimum security.

The push bar can be used independently to provide a single latching point or with additional modular locking elements to provide multiple latching points. Suitable for single and double door applications covering EN1125 and EN179.

561.SE



#### Features & Functions

- For single and double non rebated doors
- Products designed to satisfy panic exit applications or emergency exit applications
- Robust and durable construction for all heavy traffic applications
- Suitable for doors with a minimum clear opening width down to 500mm. This can be reduced to 350mm where side latches are not required
- Site reversible - easy to hand on site
- Push bar and cable covers can be cut on-site to suit door width and height
- Anti thrust device in the latch and pullmans prevents unauthorised retraction of the latches
- Shaped cross bar end piece to allow easier access to door lock
- Unique assembly reduces installation time by as much as 50%
- Easy-to-use Accufit self-adhesive templates and backplates for the individual panic devices and the pullman latches
- Fine cable adjustments allow for maximum installation accuracy
- Patented Fast-Fix cable system replaces the conventional vertical rods to connect the operating unit and the pullman latches
- Pullman latches provide a smooth and quiet closing action, ideal for interconnecting doors
- Quick and easy snap on covers



#### Certification

CE Marked to EN 1125 (AAA1589)

Fire tested to EN 1634-1 for use on fire doors up to 2hr timber

Environmental Product Declaration in accordance with ISO 14025 and EN 15803

DoP available at [www.britondops.co.uk](http://www.britondops.co.uk)

## Panic Exit Hardware - Briton 560 Series

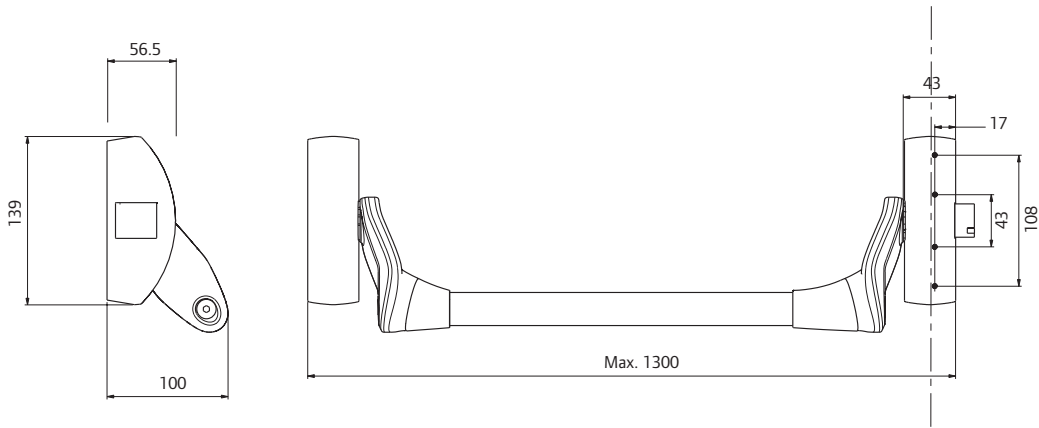

### 561

Single point latching



### 561 + 574.V

Three point latching



### 561 + 574.S

Three point latching



### 561 + 574.VS

Three point latching



### Finishes

Operating devices are available in sprayed silver with matching end boxes or with end boxes in black.



SE finish

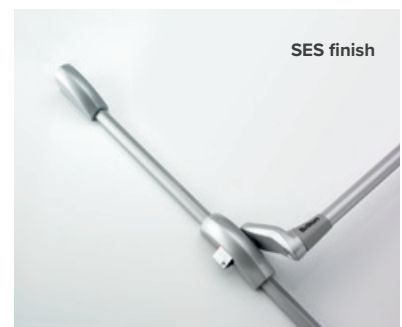

SES finish

## 560 Series

### Panic Exit Hardware

#### Introduction

The modular system of panic and emergency exit hardware allows you to add additional locking points to your device. By simply selecting your preferred device you can add up to five security points for double doors.



#### Features & Functions

- Modular components suitable for use on all Briton 560 and 570 operating devices
- Technologically advanced design with proven performance and reliability
- Suitable as standard for doors up to 2500mm high
- Cable covers can be cut on-site
- Minimal measuring is required to prepare the units to suit the door height
- Easy-to-use Accufit templates and backplates for the individual pullman latches
- Patented Fast-Fix cable system connects the pullman latches to the operating unit and allows fine cable adjustments for maximum installation accuracy
- Push on pullman latch covers are quick and simple to install

Device Type	574V	574.S	574VS.L 574VS.R	574.AS
Max. door height (mm)	2500	n/a	2500	n/a
Pullman latch vertical - top	■		■	
Pullman latch vertical - bottom	■			
Pullman latch - upper side		■		■
Pullman latch - lower side		■	■	universal



Top Pullman



Upper Side Pullman



Bottom Pullman



Lower Side Pullman

## Panic Exit Hardware - Briton 574.V, 574.S, 574.AS & 574.VS

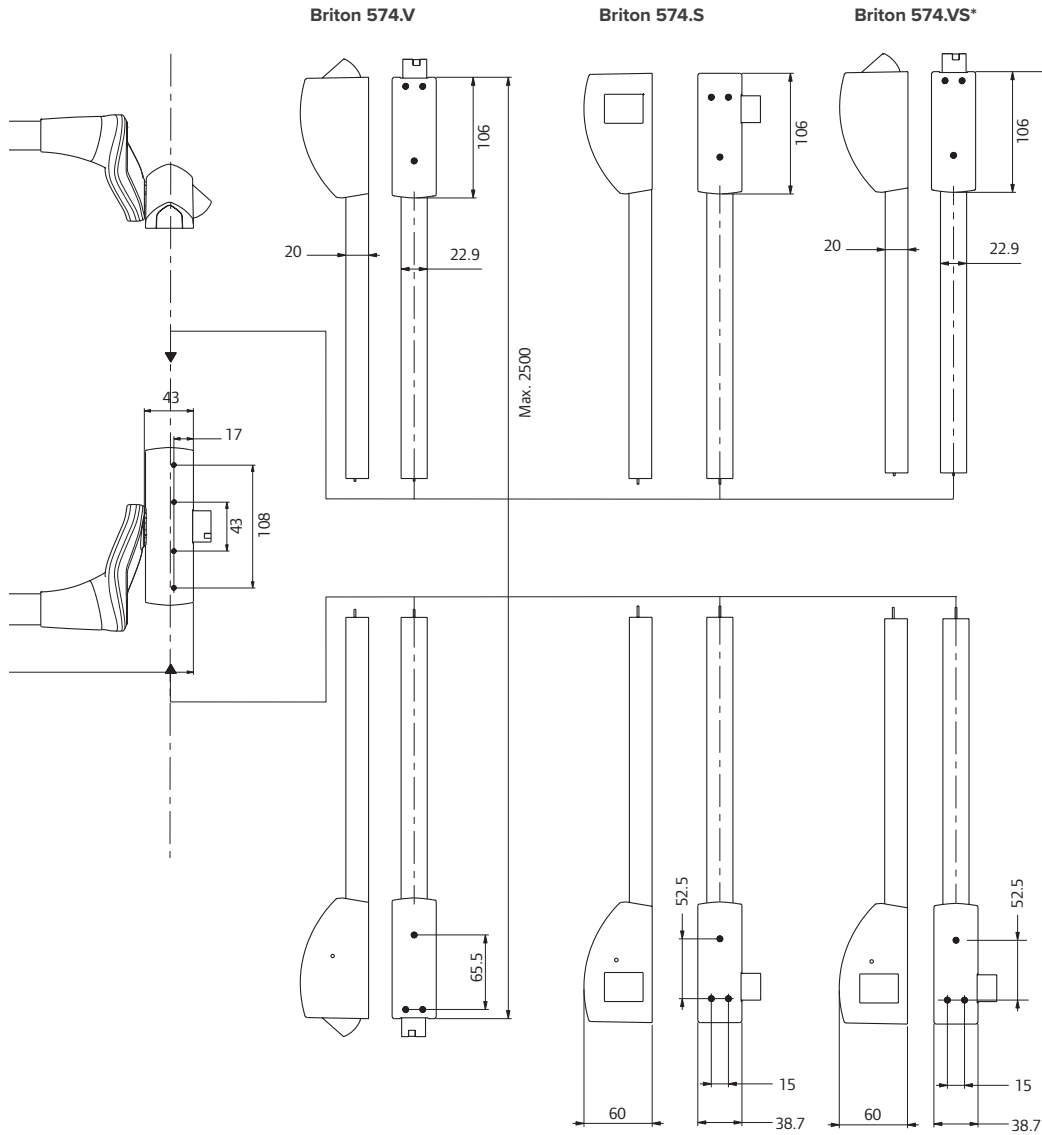

### 574.AS

Additional side pullman latches can be added to the system. These can be used at any position above or below the activation device to produce 4 point latching on a single door.

### 574.VS\*

The 574.VS kit is handed for left and right hand doors. Please check the door handing protocol below.

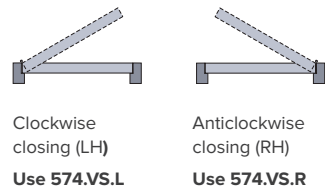

### Finishes

Touch bar is available in sprayed silver or a range of metallic finishes with sprayed silver or black chassis and end boxes.

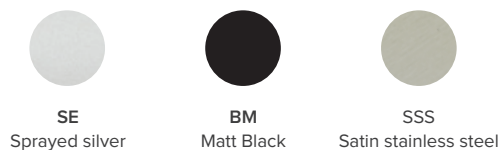

## General Maintenance

### Exit hardware

All panic hardware installation will be operated by a horizontal “Push bar” or “Touch bar” which runs across the width of the door. The operating bar will be used to operate anything from a single rim latch to multipoint side or top/bottom latches.

### MAINTENANCE AND CHECKING FUNCTION

In view of the important role the panic and emergency exit device plays in maintaining the safety and security of your building and its occupants, it is recommended that routine maintenance checks are carried out at intervals of not more than 1 month by the occupier or their approved representative.

### Types of maintenance

Much of the routine maintenance recommended consists of a combination of visual and mechanical checks, cleaning and lubrication. Look out for the icons opposite which provide a ‘quick glance’ reminder of the maintenance required.

#### Visual checks

Primarily making a visual check on the product and surrounding door/frame looking for wear, damage, and general condition.



#### Functional checks

Consists of checking that the product operates properly without any binding or undue force required. Check that any seals or weatherstripping do not inhibit correct operation of the door.



#### Check fixings

Fixings need to be checked regularly and tightened when necessary. Check that no projection of fixings prevents the door from swinging freely.



#### Lubricating

Some products will benefit from periodic lubrication using a light machine oil or as instructed.



#### Cleaning

Build up of grease, dust and harmful chemicals should be removed to prevent corrosion and maintain the product finish.



### Exit Hardware Maintenance



#### MONTHLY

Briton panic exit devices must be fitted to comply with the requirements of EN 1125 which states that the device should be easily operated by hand or body pressure in a panic situation. We suggest the following checks be made on all panic and emergency exit hardware:

- Inspect and operate the device to ensure all the components are in satisfactory working condition and operate as follows:
  - a. After being pushed the 'Push bar' or 'Touch bar' should return automatically to its initial position.
  - b. When pushed from the end casing side (hinge side of door) the latchbolt(s) should completely withdraw from their strikes as if it were pushed from the main casing side.
- **IMMEDIATE EXIT MUST BE PERMITTED.**
  - c. With the door closed, the latchbolts should be fully engaged into their strikers. They should not withdraw if pushed but should only withdraw if operated by the 'Push bar' or 'Touch bar'. The only exception to this is the additional side pullman latch available for the Briton 560-570 Series.
  - d. If necessary upper and lower, or side pullman latches can be adjusted to ensure the accuracy of latching.
- Inspect strikers and ensure they are clean and free from obstruction.
- Ensure the door closes fully into the frame and there are no obstructions.
- Check that the door has not become distorted in any way. If the door does not meet the frame stops and cannot be pulled in by the door closer the door may need to be replaced.
- Check that the door hinges are operating smoothly and lubricate if necessary.
- Check that the latches are operating freely. If necessary remove the end box covers and/or pullman latch covers and lubricate if necessary.
- Check that all fixings are tight.



**If problems persist and for some reason the panic device does not operate properly, consult your approved supplier or contact the Allegion Customer Care Team on 0330 8080 617**